



Audi India  
Division of Volkswagen  
Group Sales India Private Limited  
Mumbai - India  
www.audi.in  
Valid from June 2015

The models and equipment versions illustrated and described in this brochure and some of the services listed are not available in all countries. Some of the cars illustrated are equipped with optional features for which an extra charge is made. Details concerning the delivery specifications, appearance, performance, dimensions and weights, fuel consumption and running costs of the vehicle were correct to the best of our knowledge at the time of going to press. Deviations from the colours and shapes shown in the illustrations may occur. No liability is accepted for errors and printing errors. The right to introduce modifications is reserved. Not to be reproduced, including in part, without the written approval of AUDI AG.

U50401MH2007FTCL68439

Audi RS6 Avant

# RS 6

Audi RS6 Avant

Audi Sport  
Vorsprung durch Technik







	Page	
Fascination		
	1	Audi RS6 Avant
Technology		
	19	Audi Sport
	21	Intelligent performance
	23	quattro®
Equipment		
	31	Style guides
	33	Exterior
		Wheels/tyres
		Paint finishes
	37	Interior
		Seats
		Inlays
	43	Equipment
		Equipment packages
		Light
		Design
		Steering wheel/controls
		Comfort
		Infotainment
		Assistance systems
	47	Technology/safety
Other		
	49	Technical data
	50	Dimensions
	51	The fascination of Audi

Less weight.

**More**

driving pleasure.

There's a lot to the new Audi RS 6 Avant: inspiring power, impressive attractiveness and intelligent Audi lightweight engineering. Because a lighter car is a more agile car. The extent to which this increases your driving pleasure cannot be expressed in figures. But it can in emotions. Experience the new Audi RS 6 Avant.



Lower power-to-weight ratio.

**Higher**  
torque.

■ The outstanding power-to-weight ratio of the new Audi RS 6 Avant makes your driving even more dynamic. The enormous maximum torque of 700 Nm makes sure of that. The 4.0 litre V8 TFSI® 412 kW engine accelerates powerfully from 0 to 100 km/h in only 3.9 seconds.

The new RS 6 is not only irresistibly dynamic, it is efficient as well. Audi cylinder on demand switches four of the eight cylinders off if they are not needed - without you noticing. The engine still runs smoothly and powerfully, but needs less energy - thus reducing emissions.

Less rationality.

**More**  
feeling.



Go on, give in to your enthusiasm – the new Audi RS6 Avant deserves it. Clear, precise lines define its muscular stature, the characteristic bumper design underlines the sporty exterior. Large air inlets and the innovative Audi Matrix LED headlights are highlights at the front. At the rear, special details indicate that the RS6 is a high-performance model: the large oval-shaped tailpipe trims, for example, the striking diffuser insert and the RS6 logo on the luggage compartment lid.





■ The optional ceramic brake is visible through the optional 21-inch wheels in 5-twin-spoke design. Accentuated wheel arches and sill extensions define the vehicle's powerful side line; the RS roof edge spoiler underlines the athletic rear. The Audi Singleframe, exterior mirror housings, roof rails and the trim strim are designed in a discreet matte aluminium look.



More exclusivity.

**Fewer**  
effects.

■ Illuminated door sill trims welcome you into the new Audi RS6 Avant, and exclusive inlays in carbon emphasises the sporty atmosphere of the interior. A honeycomb pattern decorates the RS sport seats, available in Valcona leather on request, the contoured shape of which provides excellent lateral support even during challenging drives. The RS multifunction sport leather steering wheel in 3-spoke design with shift paddles in aluminium look is pleasant to grip when steering and changing gear. And you have intuitive control over many vehicle functions via the MMI® navigation plus with MMI® touch.





Enjoy the dynamism and take full control. The standard RS adaptive air suspension provides superb road handling. On request, the RS sport suspension plus with Dynamic Ride Control (DRC) further reduces the nodding and pitching movements of the vehicle. The quattro® permanent all-wheel drive with self-locking centre differential and wheel-selective torque distribution also gives you superb traction, dynamic handling and excellent directional stability. The result is uncompromisingly spirited driving.





More gears.

**Less**  
time lost.

■ The 8-speed tiptronic supports you with quick, precise gear changes – all to suit your personal style. With the Dynamic Shift Program (DSP) the transmission adapts to your driving style and changes gear at just the right moment. In addition to the Drive mode (D), the Sport mode (S) is also available, which you can use to make your driving even more dynamic. But at the same time the tiptronic also increases efficiency with its large transmission ratio spread.

In addition, Audi drive select gives you further individuality. It enables you to influence a range of vehicle components at the press of a button, for example the accelerator characteristics, the steering system and the suspension, to experience an even sportier and more balanced drive.





▀ Dynamics, power and versatility. Uniquely interpreted. It's hard to express all that's in the new Audi RS 6 Avant in just a few words. It has to be experienced – with lots of excitement. Climb in.





# Audi Sport: Technologies from motor racing. Transferred to the road.

Inspirational performance. Whether it's works motorsport, customer racing or our high-performance models - you'll not get such a potent adrenaline rush anywhere else. Audi Sport utilises the expertise gained in motor racing to bring innovative technologies to series production. With unrivalled passion - for outstanding dynamism.



# Maximum power. Put to maximum use.

## The TFSI® engine.

**Consistent power:** the 4.0 litre V8 TFSI® engine with 412 kW. With a maximum torque of 700 Nm the Audi RS 6 Avant accelerates from 0 to 100 km/h in just 3.9 seconds. The propulsive power ends at an electronically regulated 250 km/h, with the option of boosting the top speed to 280 km/h or 305 km/h.

**Intelligent performance:** with Audi cylinder on demand only four of the eight cylinders are active in partial-load operation depending on the driving conditions. The Audi valvelift system closes the intake and exhaust valves on two cylinders on each side and switches off their injection and ignition – whilst the engine continues to run as quietly as ever. As a result, neither air is drawn in nor fuel consumed – the fuel consumption and emission figures are noticeably improved. The 4.0 litre V8 TFSI® engine also features a start-stop system and recuperation. And also excels with its spontaneous responsiveness and extraordinary power delivery over the entire engine speed range.

**Powerpack:** the 8-speed tiptronic constitutes an adequate automatic transmission which boasts rapid gear changes and high efficiency. Thanks to the Dynamic Shift Program (DSP) the gear changes take place in the optimum engine speed range – reducing power flow losses while you enjoy agile motoring. The tiptronic comes with a sport program (S) or manual mode for an even more dynamic driving style.

# Superlative roadholding.

**quattro® permanent  
all-wheel drive.**

Outstanding traction, improved handling dynamics and more driving safety. Or for short: quattro®. Hardly any other drive system transfers the engine's power to the road so effortlessly.

The central component is the self-locking centre differential. The basic configuration of the purely mechanical planetary gear set distributes the drive torque asymmetrically for better driving dynamics. In a ratio of 40 : 60 between the front and rear axle. But if necessary up to 70 % can be distributed to the front or up to 85 % to the rear to offset any occurring wheel slip. Using wheel-selective torque control, the drive force is distributed to each individual wheel depending on the driving situation. What is special here is the way the effects of the torque distribution are felt before any undesirable wheel slip occurs. The result is a yawing moment which supports cornering – and thus provides precisely controlled, sporty handling with increased agility and superb traction at the same time.

By request the quattro® drivetrain can be fitted with the optional sport differential on the rear axle, in order to further enhance driving dynamics.

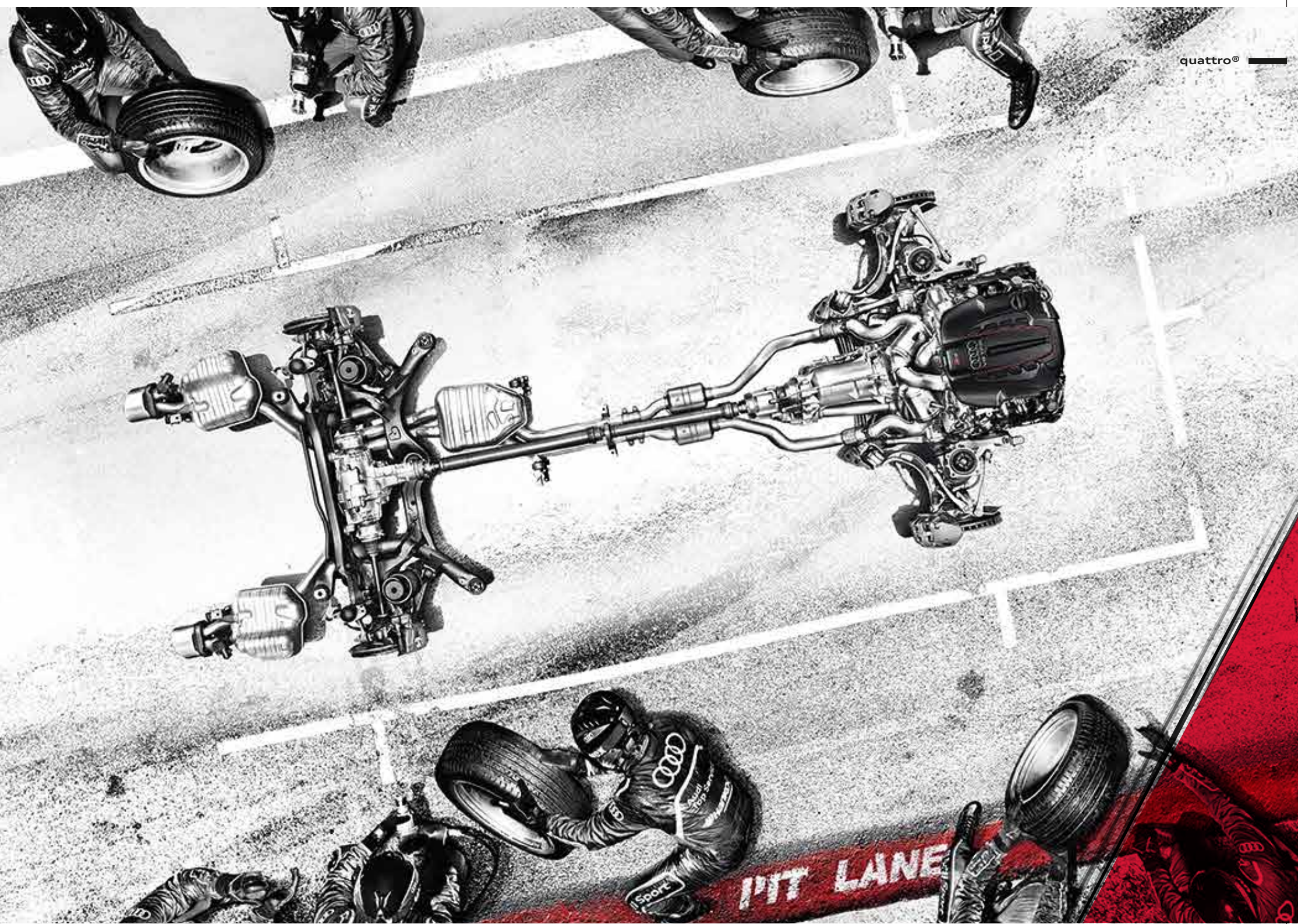

# Bending the road to your will.

## RS suspension and brake systems.

### Brake systems

Demonstrate power. With its standard 19-inch RS brake system in the Audi RS 6 Avant. The 6-piston fixed callipers at the front take a powerful hold of the wave brake discs whose cast friction ring with a wave-shaped outer contour is connected to the aluminium brake disc chamber by means of steel pins. This so-called floating mounting ensures that the friction ring remains tension-free to a major extent, thus improving stability when subjected to high temperatures. Axial perforation and cooling channels for internal ventilation increase the performance of the brake discs. The intelligent mix of materials and characteristic geometry of the friction rings help reduce weight, thus improving the balance of unsprung masses.

The optional 20-inch ceramic brake system is available for even more demanding loads. It features brake discs made out of a carbon-fibre-reinforced ceramic material which is based on hard silicon carbide with embedded high-strength carbon fibres. The result is enormous abrasion resistance, reduced weight, higher fading resistance and a long service life.

### RS suspensions

Show character. Self-assured, sporty. With the RS adaptive air suspension. Experience outstanding directional stability and excellent agility coupled with precise steering characteristics. Thanks to the 5-link front axle design. Coupled with the self-tracking trapezoidal link principle of the rear axle. Many vehicle components are made of aluminium to reduce weight and keep the unsprung masses low. The RS adaptive air suspension combines an air suspension with a variably adaptive damper system. It allows for various ride heights and simultaneously acts as a level regulator so that driving features are not compromised even with a heavy load. The upshot is dynamic handling.

The RS sport suspension plus with Dynamic Ride Control (DRC) is available as an option. Steel springs and shock absorbers with variable characteristics reduce the nodding and pitching movements around the lateral and longitudinal axes purely by hydraulic means. The diagonal dampers are connected to one another via oil pipes and one central valve each. If the dampers compress differently, for example during fast cornering, the valves regulate the oil flow to the deflected wheel. They increase support there, thus reducing side tilt and enhancing driving dynamics.

The electromechanical power steering with RS-specific characteristic curve provides additional dynamism. Thanks to the low-position configuration, the steering forces are conducted just a short distance to the wheels, which provides a spontaneous steering response, precise feedback from the road and even more fun on bends. The steering also requires almost no energy when driving in a straight line, thus helping to reduce fuel consumption.



# Reach your destination. The way you want.

Audi drive select.

Change character. With the standard Audi drive select in the Audi RS 6 Avant. Individual vehicle components can be influenced at the push of a button – such as the accelerator pedal characteristic curve, exhaust flap control, transmission mode, the damper regulation of the RS adaptive air suspension and the steering torque of the electromechanical power steering – to adapt them to the prevailing driving situation. With four different modes including various settings: auto, comfort, dynamic and individual; auto for superior sporty quality, comfort for longer journeys, dynamic for more ambitious driving, and individual, so you configure the individual components yourself according to your preferences.

In addition, various optional systems can be influenced. For example, the characteristic curves of the shock absorbers on the RS sport suspension plus with Dynamic Ride Control (DRC) can be varied in three levels: from balanced rolling in comfort mode through to sporty, direct responsiveness in the dynamic setting. The dynamic steering can also be varied. The power steering assistance and ratio are changed depending on the road speed and the Audi drive select mode chosen. The optional quattro® with sport differential also allows additional infinitely variable distribution of the drive forces between the rear wheels. This torque manipulation specifically influences the vehicle's steering behaviour and increases agility even further. The adaptive cruise control response can also be set to be either more gradual or more spontaneous.

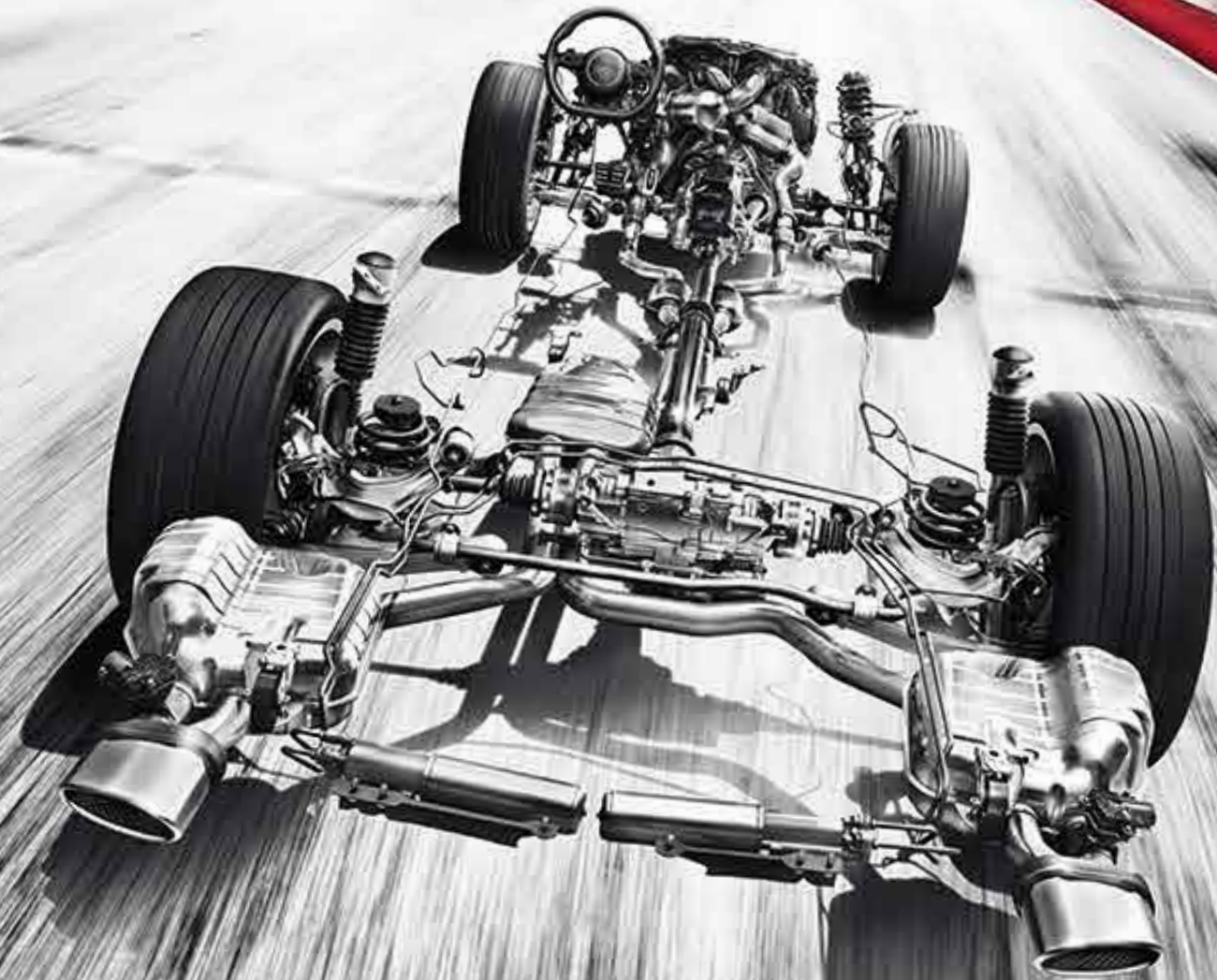



**As unique as you are.  
The equipment options.**

Sportiness, comfort, design, functionality – whatever you demand of your Audi, it offers you a wealth of custom options. Audi equipment versions are varied and high-quality and you can tailor them entirely to your needs.

## Character takes on many forms. Here are two of them.

What makes an Audi your Audi? Vehicle equipment entirely tailored to your needs. There are a wide range of options available to you for giving your vehicle the exact touch you have in mind. More sportiness? More elegance? Let yourself be inspired.

### Audi RS 6 Avant in Misano red, pearl effect

Cast aluminium wheels in 5-twin-spoke design  
in gloss black, gloss turned finish\*

Carbon styling package including air inlet duct with  
quattro® logo

Exterior mirror housings in carbon

RS sport exhaust system

RS sport seats, front, with Audi exclusive design package  
in Valcona leather, black, with honeycomb pattern in  
crimson red

Carbon inlays



\* Optional



### Audi RS 6 Avant in Sepang blue, pearl effect

Forged aluminium wheels in 7-twin-spoke design, gloss  
turned finish

Matt aluminium-look styling package including air inlet  
duct with quattro logo

RS sport seats, front, in Valcona leather, lunar silver,  
with honeycomb pattern in rock grey

RS multifunction sport leather steering wheel in 3-spoke  
design, flattened at the bottom

Inlays in piano finish, black



## Your Audi is painted not just once. But several times.

Choose the paint finish to suit your individual taste. But whichever colour you opt for, you can count on the outstanding quality of our painting process. Though no thicker than a human hair, the layer of paint on an Audi is actually made up of four different coats. And with a matte effect paint finish as many as six, it ensures that your Audi is optimally protected from environmental influences and wear. And also outwardly reflects your personality.



### | Solid paint finish



Nardo grey

### | Metallic paint finishes



Glacier white, metallic

### | Pearl effect paint finishes

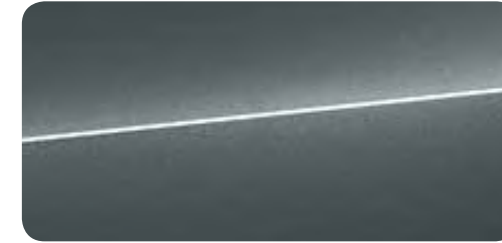

Daytona grey, pearl effect

### | Crystal effect paint finishes



Prisma silver, crystal effect

### | Matte effect paint finish

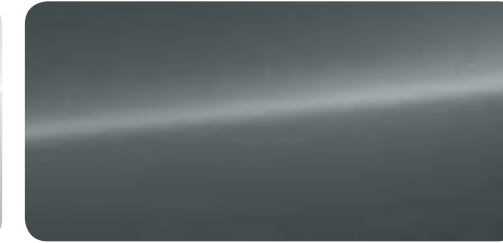

Daytona grey, matte effect\*



Floret silver, metallic



Misano red, pearl effect



Panther black, crystal effect



### | Customised paint finishes

Audi exclusive customised paint finishes



Mythos black, metallic



Sepang blue, pearl effect

\* Optional at additional cost



## The perfect connection between an Audi and the road: Audi wheels and tyres.

To make sure you have peace of mind for every metre of your drive, Audi puts its wheels through an exacting series of specialised test procedures. Hardness tests, for example, aim for maximum stability, while a copper accelerated salt spray test – CASS for short – using acetic acid guarantees the greatest possible corrosion protection. Thanks to these and many other measures, we can ensure that every Audi wheel offers maximum quality – even after scores of kilometres. No matter which of the numerous designs you choose.

### | Summer wheels



**Forged aluminium wheels**  
in 7-twin-spoke design, gloss turned finish  
size 9.5 J x 20 with 275/35 R 20 tyres



**Cast aluminium wheels**  
in 5-twin-spoke design in matte titanium look,  
gloss turned finish\*  
size 9.5 J x 21 with 285/30 R 21 tyres



**Cast aluminium wheels**  
in 5-twin-spoke design\*  
size 9.5 J x 21 with 285/30 R 21 tyres



**Cast aluminium wheels**  
in 5-twin-spoke design in gloss black,  
gloss turned finish\*  
size 9.5 J x 21 with 285/30 R 21 tyres

**Tyre pressure monitoring system**  
monitors the air pressure set in the tyres and the tyre temperature throughout the journey, also works with winter wheels delivered by Audi. Air pressures and temperatures of the individual wheels can be displayed in the MMI® system.

\* Optional

## Premium quality you can rely on.

You have a special place in your Audi. Exclusivity can be felt on the front and rear seats: thanks to high-quality materials and first-class workmanship. No matter which seat upholstery you decide on and whether you prefer the RS sport seats with stable lateral support for dynamic driving or the customised contour seats: you're sitting in the right place.



**RS sport seats, front** <sup>1</sup>

The illustration shows RS sport seat, front, electrically adjustable<sup>1</sup>, in Valcona leather, black, with honeycomb pattern in rock grey.



**Customised contour seats, front\*** <sup>2</sup>

including memory function for driver and front-passenger seat, electric steering wheel adjustment and exterior mirrors. The illustration shows customised contour seat with seat ventilation, front, perforated in Valcona leather, black.

\* Optional

### | Leather

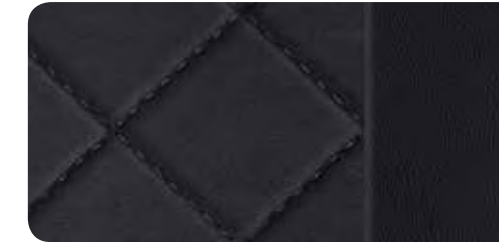

**Alcantara/leather, black with diamond pattern in black**



<sup>1</sup> **Valcona leather, black with honeycomb pattern in black\***

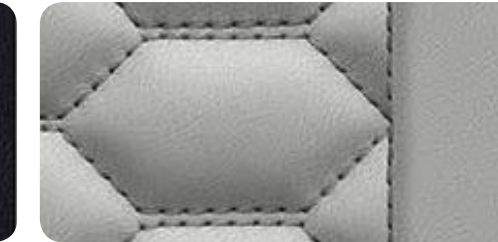

<sup>1</sup> **Valcona leather, lunar silver with honeycomb pattern in rock grey\***



<sup>1</sup> **Audi exclusive leather upholstery and trim** <sup>1</sup> <sup>2</sup>  
Individual choice of colour for leather/stitching/piping



**Valcona leather, black\***



<sup>2</sup> **Valcona leather, black with honeycomb pattern in rock grey\*** <sup>1</sup>



**Valcona leather, black perforated\*\***



<sup>2</sup> **Audi exclusive Valcona leather, black, with honeycomb pattern in crimson red\*** <sup>1</sup>

\* Optional

### | Seat options

- <sup>1</sup> RS sport seats, front
- <sup>2</sup> Customised contour seats, front

**| Leather upholstery and trim****Alcantara/leather combination**

for RS sport seats, front; seat centre panels and door trim inserts in Alcantara as well as seat side bolsters, head restraints, centre armrest, front as well as lower part of centre console in leather; seat centre panels on the front seats and outer rear seats with diamond pattern; RS 6 embossing on the front-seat backrests

**Valcona leather upholstery and trim with honeycomb pattern\***

for RS sport seats, front: seat upholstery, head restraints, door trim inserts and centre armrest, front in Valcona leather; lower part of centre console in leather; seat centre panels on the front seats and outer rear seats with honeycomb pattern; RS 6 embossing on the front-seat backrests

**Valcona leather upholstery and trim\***

for customised contour seats, front: seat upholstery, head restraints, door trim inserts and centre armrest, front in Valcona leather; lower part of centre console in leather; in conjunction with seat ventilation, front, seat centre panels of the front seats and the outer rear seats are perforated

**| Seating comfort****Front seats, electrically adjustable, including memory function for the driver seat**

with electric adjustment of seat height, fore/aft position, seat and backrest angle as well as electric 4-way lumbar support; 2 pre-sets for the electrically adjustable driver seat, the electric steering wheel adjustment and the exterior mirrors

**| Seats in the rear****RS sport seats in the rear**

2 single seats in the rear with shaped seat side bolsters and integrated head restraints, visually matched to the front seats; rear seat backrest can be split-folded 40 : 60 or fully; with remote backrest release in luggage compartment; rear seat bench with integrated storage compartment in the centre

**Rear seat system with 3 seats\***

visually matched to the front seats; 3 L-shaped rear head restraints, height manually adjustable; rear seat backrest can be split-folded 40 : 60 or fully; with remote backrest release in luggage compartment; including fold-out centre armrest with storage compartment and 2 cup holders



## Experience fascination. Down to the last detail.

The exclusive Audi inlays emphasise the sporty ambience of your vehicle. At first sight. Be inspired by refined carbon, aluminium, piano finish or wood for the dashboard, centre console and door trims. High quality and precise workmanship harmoniously integrated in the interior.



### | Inlays



**Carbon**  
all-round inlay and surrounds for the door trims and centre console in aluminium look



**Aluminium Race\***  
all-round inlay and surrounds for the door trims in aluminium look



**Piano finish, black\***  
all-round inlay and surrounds for the door trims and centre console in aluminium look



**Matte brushed aluminium\***  
all-round inlay and surrounds for the door trims in aluminium look



**Aluminium/Beaufort, black\***  
all-round inlay and surrounds for the door trims and centre console in aluminium look



**Audi exclusive wood inlays**  
all-round inlay and surrounds for the door trims and centre console in aluminium look

### Inlays

full-surface for dashboard, door trims and centre console

### Audi exclusive wood inlays\*

available in fine grain ash, nougat, oak sepia, fine grain myrtle, nutmeg, vavona bronze, modrone gold, tamo ash, natural dark brown

\* Optional



## | Equipment packages

### Dynamic package plus\*

includes:

- ceramic brake
- dynamic steering
- quattro® with sport differential
- RS sport suspension plus with Dynamic Ride Control (DRC)
- increase of maximum speed to 305 km/h

## | Headlights/interior lighting

### Audi Matrix LED headlights

The innovative technology combines a camera system with LED light sources and precision optics for highly adaptive light distribution. The system blanks out light that would otherwise shine directly on oncoming vehicles or vehicles in front but continues to fully illuminate all the other areas in between and alongside. The front lighting thus adapts dynamically, providing the driver with a much wider visual range. The conventional division between dipped and high beam is dispensed with. Familiar convenience functions such as the static turning light, all-weather light, junction light, motorway light and travel mode, which uses GPS data to switch between right- and left-hand drive modes are integrated into the LED technology. The LEDs of the Audi Matrix LED headlights also perform the dynamic cornering light functions. Using vehicle support based on navigation data, it starts responding shortly before the steering wheel is turned. Distinctive features include the crisp lighting pattern with matte black frame and horizontal web in glacier white, the LED daytime running lights and the dynamic indicator in the headlights and rear lights.



### LED rear lights with dynamic indicator

brake lights, tail lights, rear fog lights, indicators and rear number plate lights in low-energy LED technology; with reversing lights in white and third brake light integrated in the RS roof edge spoiler; with dynamic, clearly visible actuation of the indicators: the segments of the LED light band are illuminated in turn within milliseconds, creating a pulse of light that runs outwards in the direction in which the car is turning. When operated, the indicators send a distinctive signal to other road users

### Ambient lighting

including integrated eyewear compartment in the roof module; ambient lighting can be configured via the MMI®

- with delayed switch-off and contact switches on all doors
- glove compartment lighting
- luggage compartment lighting
- courtesy lighting in the luggage compartment lid
- active door reflectors

In LED technology:

- courtesy lighting on the underside of the door handles and handle recess lighting
- entrance lighting, front and rear
- 2 reading lights each at the front and rear
- lighting for door pockets, inside door handles, vanity mirrors and footwell
- ambient lighting for centre console and door inner panels to help occupants better orient themselves

## | Exterior design

### Model name/logo

RS 6 logo in the Audi Singleframe and on the luggage compartment lid

### Audi Singleframe

with radiator grille with honeycomb design in high-gloss black and one-piece trim frame in a matte aluminium look

### RS bumpers

in a sporty dynamic design; at the front with large air inlets and side flaps in high-gloss black, as well as front spoilers in matte aluminium look, at the rear with diffuser insert in high-gloss black

### Wheel house extensions

front and rear

### Sill extensions

painted in body colour

### Trim strips

on the side windows in matte aluminium look; cover strips, B-pillar trims and triangular panels on the rear doors in high-gloss black

### Roof rails in matte aluminium look

for safe transportation of items, strong and aerodynamically shaped

### RS roof edge spoiler

on the luggage compartment lid

### Engine cover with carbon trim

side inlays of the engine design cover in carbon

### Matte aluminium styling package including air inlet duct with quattro® logo\*

side flaps and top edge of the rear diffuser insert in matte aluminium look; including air inlet duct in the Audi Singleframe in matte aluminium look with quattro logo in titanium grey

### Gloss black styling package including air inlet duct with quattro® logo\*

front spoiler, frame of the radiator grille and trim strips on the side windows in high-gloss black; including air inlet duct in the Audi Singleframe in high-gloss black with quattro® logo in titanium grey; roof rails in matte black

### Carbon styling package including air inlet duct with quattro® logo\*

front spoiler, side flaps and rear diffuser insert in carbon; including air inlet duct in the Audi Singleframe in carbon with quattro® logo in titanium grey; frame on the radiator grille and trim strips on the side windows in high-gloss black, roof rails in matte black

## | Interior design

### Aluminium-look interior

on light switches, window controls and mirror adjustment switch, air conditioning, MMI® rotary/push button control including MMI® control buttons, the air vents and selector lever gaiter

### Door sill trims with aluminium inlays

and illuminated RS 6 logo

## | Steering wheel/controls

### RS multifunction sport leather steering wheel in 3-spoke design, flattened at the bottom

adjustable in height and reach; with shift paddles in aluminium-look, RS 6 emblem and full-size airbag; flat-bottomed steering wheel rim upholstered in perforated leather and contrasting stitching in rock grey; for operating the infotainment features fitted in the vehicle

### Electric steering wheel adjustment

adjustable in height and reach, with automatic entry and exit function

### RS selector lever knob in perforated leather

with RS logo and decorative ring in aluminium look; selector lever gaiter in leather with contrasting stitching in rock grey



## | Mirrors

### Exterior mirrors with integrated LED indicator

electrically adjustable  
The automatic kerb-side function tilts the exterior mirror on the passenger side downwards when reverse gear is selected, giving the driver a better view of the kerb.

### Electrically folding and automatically dimming on both sides, with memory function

including automatic kerb-side function for the exterior mirror on the passenger side



### | Roof system

#### Panoramic glass sunroof

2 sections, electrical activation to raise and open the front glass section; tinted glass insert and an electrically operated sunblind as well as convenience closing/opening via vehicle key; ensures a comfortable interior that is flooded with light; improved interior climate by means of efficient ventilation

### | Glazing

#### Heat-insulating glass

green-tinted windscreen and front side windows with acoustic glazing for improved noise insulation; rear window heated, with timer

#### Manually operated sunblind

for the rear window and the rear door windows

### | Climate control

#### 4-zone deluxe automatic air conditioning

- with indirect ventilation and sunlight-dependent control
- electronically regulates the air temperature, flow rate and distribution
- humidity sensor
- combined/fine particulate filter
- automatic recirculation mode by means of air quality sensor
- use of residual heat
- separate regulation of footwell temperature
- ventilated glove compartment
- front air-conditioning controls with digital display
- separate temperature control for driver and front-passenger sides
- ventilation in the rear via the centre console
- air vents in the B pillars
- additional air-conditioning controls with digital display for climate control in the rear with separately adjustable temperature and blower settings and air distribution for the left and right-hand sides (rear functions can also be set from the front air-conditioning controls)
- choice of 3 climates: gentle, medium, intensive
- key-coded settings

### | Closing systems

#### Convenience key\*

access and drive authorisation system, the key only needs to be carried with you; the vehicle is locked and unlocked from outside via sensors on all door handles. The luggage compartment lid can also be opened separately when the vehicle is locked

#### Luggage compartment lid, electrically opening and closing

opening via a button on the vehicle key or in the driver's door or using the soft-touch button in the luggage compartment lid handle recess; closing via button on the inside of the luggage compartment lid, the button in the driver's door or via the optional convenience key (long press). In conjunction with the convenience key, it is possible to close the luggage compartment lid and simultaneously lock the car via an additional button on the inside of the luggage compartment lid. Including servo closing and programmable luggage compartment lid opening angle as well as an electrically opening and closing luggage compartment cover, can also be operated manually

#### Convenience key including sensor-controlled release of the luggage compartment lid\*

features as for convenience key. Moving your foot (in a kicking motion) below the rear bumper causes the luggage compartment lid to swing open automatically if the vehicle key has been detected

#### Power-assisted door closing\*

automatically pulls the doors into the locks when not fully closed

### | Storage/transport

#### Storage compartments

storage compartment in the door trims, storage net on the front-seat backrests, storage compartment under the front seats (not in conjunction with customised contour seats, front) and in the centre console; glove compartment on the front-passenger side, lockable, large-volume, illuminated, with holder for writing utensils; 2 cup holders on the centre console and one 12V socket

#### Storage package

luggage compartment net for attaching objects to the lashing points on the luggage compartment floor, additional 12V socket in the rear

#### Luggage compartment

large-volume, with large through-loading width; including side net and 12V socket on the right-hand side of the luggage compartment; retaining straps on the left-hand side of the luggage compartment; bag hooks on the left and right; 4 lashing points on the floor of the luggage compartment; luggage compartment cover

#### Through-loading facility

for the practical transportation of long items; including rear centre armrest, foldable with storage compartment and 2 cup holders

### | MMI®/navigation

#### RS instrument cluster

with black dials, red needles, white scales, RS 6 logo in the rev counter and dynamic ready-check feature

#### Driver information system with colour display

high-resolution 7-inch TFT colour display directly in the driver's field of vision; displays information from the MMI® system, infotainment systems and driver assistance systems; display of trip computer with short and long-term memory, digital speedometer, gear display, outside temperature, plus door and luggage compartment lid check; RS menu with shift light, charge pressure and oil temperature display as well as lap timer; can be operated via an RS multifunction sport leather steering wheel; including attention assist: attention assist warns the driver in the form of an acoustic signal and a visual warning, if it has evaluated that the driver's attention is lapsing

#### MMI® navigation plus with MMI® touch

- navigation system including map updates
- electrically extending, high-resolution 8-inch colour display
- 3D map display
- detailed route information: map preview, choice of alternative routes, POIs, lane recommendations, motorway exits, detailed junction maps, and much more
- MMI® touch: touch-sensitive control panel for rapid, intuitive operation, e.g. destination entry using handwriting recognition function as well as ability to move and zoom freely on the map
- voice control system enables operation by means of whole-word entry of address in one sentence
- access to smartphone voice control
- driver information system with 7-inch colour display including display from navigation map
- vehicle support and speed limit display based on navigation data function
- country information, e.g. on valid speed limits, motorway sticker requirement when passing the border, etc.
- MMI® radio plus
- flash memory for music (10 GB)
- DVD drive (MP3, WMA, AAC and MPEG-4-compatible) for music CDs and video DVDs
- 2 SDXC card readers
- Audi music interface for connecting portable media players via the USB interface
- Bluetooth interface for hands-free function and audio streaming
- display of emails and messages from mobile phone in selected languages including text-to-speech function

### | Entertainment

#### Audi music interface

portable media players such as Apple iPod/iPhone (music functionality) as well as USB storage media and MP3 players can be connected to the vehicle via USB interface (including power supply/charge function) is located in the centre console; operation via MMI® or RS multifunction sport leather steering wheel. Part of MMI® navigation plus with MMI® touch

#### DVD/CD changer\*

for 6 DVDs or CDs; supports e.g. audio CDs, video DVDs; shock-resistant location in the glove compartment and can be operated via MMI®

#### Bose Surround Sound

impressive reproduction of 5.1 surround sound thanks to 12-channel amplifier with total output of over 600 watts and 14 loudspeakers including centre speaker and subwoofer; AudioPilot® for noise-dependent volume adjustment and powerful and accurate bass reproduction, lifelike sound with natural tone and a feeling of space for an outstanding sound experience

#### Bang & Olufsen Advanced Sound System\*

exhilarating reproduction of 5.1 surround sound with 15 loudspeakers including centre speaker and subwoofer each with its own amplifier channel. The efficient 15-channel DSP all-digital amplifier; all-digital highly efficient 5-channel ICE-Power amplifier for woofers and subwoofers; with total output of over 1,200 watts. Polished loudspeaker covers in aluminium and automatically extending acoustic lenses for excellent sound performance and perspective from every seat, with noise-dependent volume adjustment. Privacy function provided by encapsulated loudspeaker casings which minimise the escape of sound to the outside of the vehicle and provide privacy, for example when making phone calls

\* Optional

### | Assistance systems

#### Auto release function

holds the vehicle stationary for unlimited periods after stopping in traffic on normal uphill or downhill gradients. The system is activated by push-button and allows the driver to drive away smoothly

#### Parking system plus

acoustic and visual parking system, front and rear, assists with parking and manoeuvring. Information shown in the MMI® display; measurement by ultrasonic sensors concealed in the bumpers; activated when reverse gear is selected or via the button on the centre console

#### Reversing camera

image of area behind the vehicle shown on the MMI® display, with dynamic display elements showing the calculated path depending on steering angle; auxiliary lines and guidelines and identification of the point at which to apply opposite lock when parallel parking; reversing camera integrated discreetly in the handle strip of the luggage compartment lid; activated when reverse gear is selected or via the button in the centre console

#### 360 degree cameras\*

safe pulling out of narrow parking spaces. Various display options for the area around the vehicle, including a virtual top view, can be selected on the MMI® display. The driver can select between different image views in the MMI® display: reversing image, front camera image, front and rear side view as well as bird's eye view. Including the scopes of the reversing camera; activated when reverse gear is selected or via a button on the centre console

#### Audi pre-sense basic

automatically initiates preventive occupant protection measures where necessary; these include: belt tightening, activating the hazard warning lights and closing the panoramic glass sunroof and windows; categorises driving situations by networking the different vehicle systems

#### Cruise control

at speeds from around 30 up to 250 km/h, the system keeps the set speed constant provided that engine power and engine braking effect permit it; operated via separate steering column stalk, set speed displayed in driver information system

#### Head-up display

projects as required information relevant to the driver from the assistance systems, navigation or the RS menu of the driver information system, as well as warning symbols onto the windscreen in the driver's direct field of vision. The height-adjustable head-up display provides a multicoloured display with good contrast and minimal distraction from the road. Activation using the button next to the light switch

\* Optional

### | Driving dynamics/brakes

#### Audi drive select

features different modes – comfort, auto, dynamic and individual – which allow you to change the vehicle's characteristics by adapting the power steering assistance, accelerator or gear-change characteristics, RS adaptive air suspension, exhaust flap control and the settings of optional equipment

#### RS adaptive air suspension

automatically regulates the vehicle height and damping by means of the electronically controlled air suspension with infinitely variable adaptive damping system on all 4 wheels; with RS 6-specific tuning; includes ride height control and manual lift function; various modes can be selected via Audi drive select

#### RS sport suspension plus with Dynamic Ride Control (DRC)

adjustable in 3 stages; single-tube gas-filled shock absorbers with variable suspension characteristics and coil springs; control range of Dynamic Ride Control (DRC) can be selected in 3 stages via Audi drive select: comfort, auto, dynamic

#### quattro®

permanent all-wheel drive with self-locking centre differential and asymmetric/dynamic torque distribution, as well as wheel-selective torque control and Electronic Differential Lock (EDL); distributes the drive forces depending on the driving situation to each individual wheel for precisely controlled, sporty handling; quattro® emblem in the dashboard on the passenger side

#### quattro® with sport differential

the electronically controlled sport differential distributes variable amounts of drive force to each rear wheel and ensures outstanding acceleration performance in corners and stabilises the vehicle's response to load change. It also improves direct steering characteristics and provides more agile handling due to the lower steering effort required

#### tiptronic

8-speed automatic transmission with Dynamic Shift Program (DSP) and sport program; option of manual control via shift paddles on the RS multifunction sport leather steering wheel or by nudging the selector lever

#### Dynamic steering

when cornering, changing lanes or parking, for example, this system improves handling and ride comfort by dynamically regulating steering according to the driving situation; in addition to adaptation of the steering effort, the steering angle is also adapted (steering ratio); also supports vehicle stabilisation through ESC

#### RS brake system

19-inch diagonally-split high-performance brake system, Antilock Brake System (ABS) with Electronic Brake Force Distribution (EBD), Electronic Stabilisation Control (ESC) with brake assist, aluminium tandem brake booster, wave brake discs ventilated at front and rear, perforated and with floating mounting; brake callipers painted in high-gloss black with RS logo at front

#### Brake callipers painted in high-gloss red

for RS brake system, with RS logo front and rear

#### Ceramic brake

20-inch high-performance brake system with carbon-fibre reinforced ceramic brake discs and brake callipers painted in high-gloss anthracite and featuring the 'Audi ceramic' logo; ventilated and perforated brake discs with special cooling channels

#### Increase of maximum speed to 280 km/h electronically regulated

### | Technology/safety

#### Electronic Stabilisation Control (ESC)

with sport mode, can be deactivated in 2 stages; provides better stability at any speed through targeted braking of individual wheels and intervention in the engine management system; networks the ABS, EBD, ASR and EDL with its own sensors and compares the driving data with reference data

#### RS sport exhaust system

for an enhanced acoustic experience: dual-branch, with high-gloss black oval tailpipe trims

#### Recuperation

economises on fuel through brake energy recovery; kinetic energy is converted into usable electrical energy by increasing the generator voltage when the vehicle is coasting or braking and relieving the generator during subsequent acceleration

#### Start-stop system

helps to reduce fuel consumption and CO<sub>2</sub> emissions by automatically switching off the engine when the vehicle is stationary, e.g. at traffic lights. The start process is initiated as soon as the foot brake is released. Can be deactivated via a switch at any time

#### Airbags

full-size airbags for driver and front passenger; in conjunction with ISOFIX child seat mounting for the front passenger seat including deactivation switch for front passenger airbag

#### Side airbags, front and head airbag system

front side airbags integrated into the seat backrests; with additional head airbag system: unfolds over the entire length of the side windows to protect front and rear passengers in the event of a side impact

#### Side airbags, rear

to supplement side airbags at the front and head airbag system

Equipment packages Light Design Steering wheels/controls Comfort Infotainment Assistance systems Technology/safety



Model	RS 6 Avant
Engine type	V8 petrol engine with direct fuel injection and turbocharging
Displacement in cc (valves per cylinder)	3,993 (4)
Max. output <sup>1</sup> in kW at rpm	412/5,700-6,600
Max. torque in Nm at rpm	700/1,750-5,500
<b>Power transmission/wheels</b>	
Drive type	quattro® permanent all-wheel drive
Transmission type	8-speed tiptronic
Wheels	Forged aluminium wheels, 9.5 J x 20
Tyres	275/35 R 20
<b>Weights/capacities</b>	
Unladen weight <sup>2</sup> in kg	2,025
Gross vehicle weight in kg	2,580
Fuel tank capacity, approx. in l	65
<b>Performance/consumption<sup>3</sup></b>	
Top speed in km/h	250 <sup>4</sup>
Acceleration 0-100 km/h in s	3.9
Fuel grade	Sulphur-free SuperPlus RON 98 <sup>5</sup>
Fuel consumption <sup>6</sup> in l/100 km combined	9.6

**Explanatory notes**

- <sup>1</sup> The figure given was calculated using the specified measuring procedure (current version of UN-R 85).
- <sup>2</sup> Unladen weight includes driver (75 kg) and fuel tank 90% full, calculated in accordance with the current version of Reg. (EU) 1230/2012. Optional equipment may increase the car's unladen weight and drag co-efficient, whereupon the possible payload limit and the top speed will be reduced accordingly.
- <sup>3</sup> A vehicle's fuel consumption and CO<sub>2</sub> emissions do not just depend on how efficiently the vehicle uses the fuel, but are also influenced by driving behaviour and other non-technical factors. CO<sub>2</sub> is the greenhouse gas primarily responsible for global warming.
- <sup>4</sup> Regulated.
- <sup>5</sup> We recommend using sulphur-free SuperPlus unleaded RON 98 fuel complying with DIN EN 228. If this is not available, use sulphur-free super unleaded RON 95 fuel in accordance with DIN EN 228; power output will be slightly reduced. Unleaded RON 95 fuel with a maximum ethanol content of 10% (E10) can generally be used. Fuel consumption details refer to operation with RON 95 fuel in accordance with 692/2008/EC.
- <sup>6</sup> The figures given was calculated using the specified measuring procedures. The figures do not refer to one individual vehicle and do not form part of any offer, but rather should be used purely for purposes of comparison between the different vehicle models.

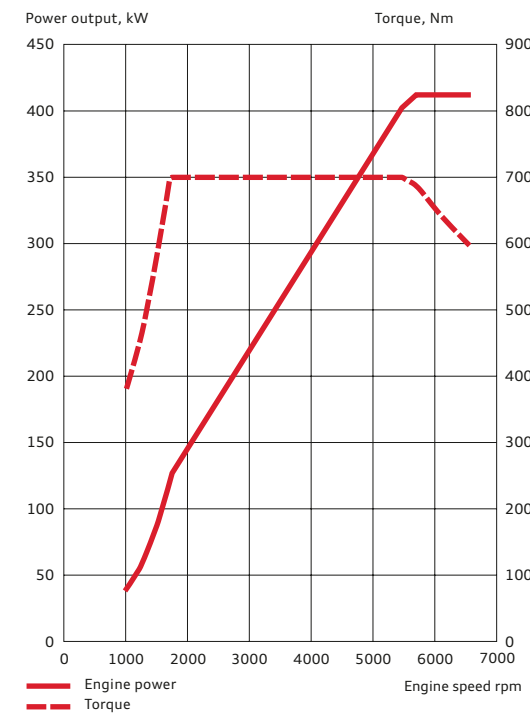
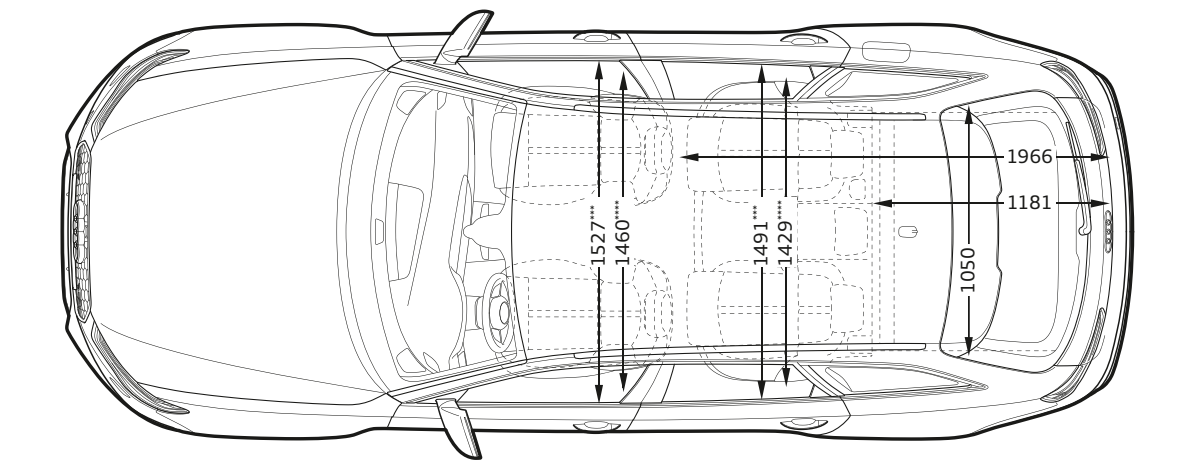
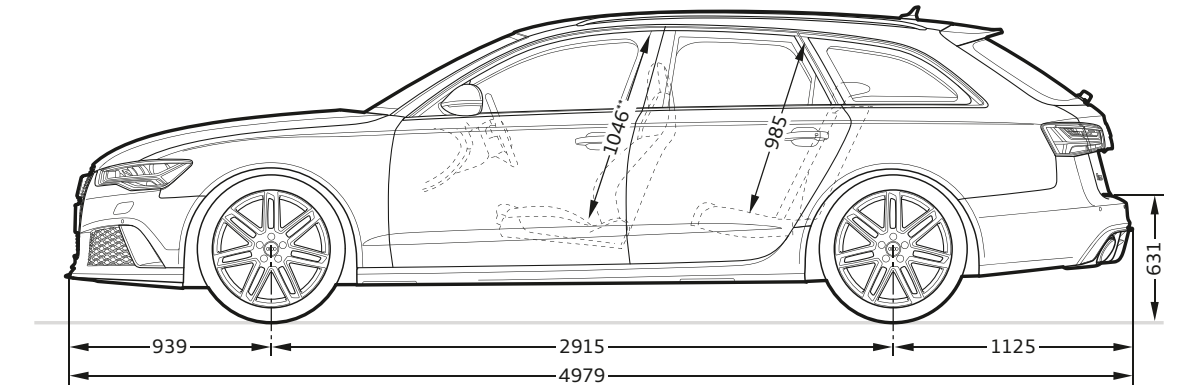
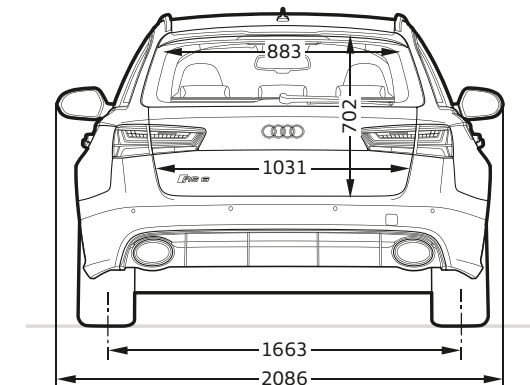
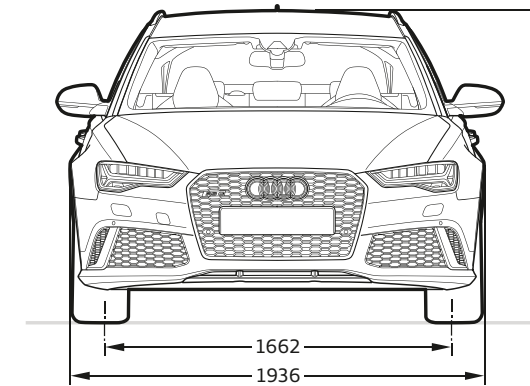
**Audi RS 6 Avant****Dimensions in millimetres.**

Dimensions were measured with vehicle at unladen weight.

Luggage capacity 565/1,680 l (second value with the rear seat backrest folded down and vehicle loaded up to roof height).

Turning circle approx. 11.9 m.

\*With roof aerial the height of the vehicle is 1,482 mm. \*\*Maximum headroom.

\*\*\*Elbow room width. \*\*\*\*Shoulder room width.



## Responsibility

Living up to our responsibilities is a principle that is firmly anchored in Audi strategy. Alongside commercial success and international competitiveness, our responsibility toward company employees and society as a whole is a key consideration, as is protecting the environment and conserving resources. And what is true in the details – our catalogues are printed on FSC-certified paper – also holds in general: Audi develops cars that are not only sporty and emotive but also ever more efficient. In the long run, Audi

wants its products to allow CO<sub>2</sub>-neutral mobility. Seeing to it that production in Audi plants gradually becomes CO<sub>2</sub>-neutral is another aspect of our comprehensive approach. Audi is also committed to society – particularly in the fields of education, technology and social projects. At Audi, sustainability is closely linked with how we see the future: the Audi Urban Future Initiative sees Audi working with international experts to get to the root of future urban challenges and trends in mobility.



# Discover the world of Audi.



## The Audi experience

The fascination of Audi can be experienced in many different ways. Audi City London, for example, gives you digital access to all models at their actual size and in real time. And of course it is always worth visiting one of the major motor shows. This is where Audi always presents its new models here and invites you to take a look at how the future is being shaped with 'Vorsprung durch Technik'. Anyone interested in seeing how Audi is already putting this into practice will find fascinating insight in the 'Vorsprung durch Technik' online special at [www.audi.com](http://www.audi.com). But a look back can also be rewarding: at the Audi museum mobile in Ingolstadt, history and high-tech go hand in hand. A total of 130 historic exhibits and state-of-the-art

forms of presentation make for a thrilling symbiosis. Plus, Audi driving experience allows you to live the excitement and countless possibilities of current Audi models. Here, pure driving enjoyment is combined with valuable learning effects. This is ensured by a team of specially trained and highly qualified instructors who provide practical tips to help you optimise your driving skills. All this can now also be enjoyed at the recently opened Audi driving experience center in Neuburg, near Ingolstadt. Facilities here include a circuit of up to 3.4 kilometres that features challenging combinations of bends, a 30,000 m<sup>2</sup> dynamic driving area and an offroad section where Q models can be put through their paces.



Choosing an Audi means choosing a brand that offers more. More individuality. More exclusivity. More fascination.



## Team spirit

Motorsport is a driving force behind the brand. For years Audi has been among the champions in various racing series, for instance the 24 Hours of Le Mans or the DTM German Touring Car Masters. The values that are crucial in many different areas of sport are also central ones for Audi: precision, passion and technology. No coincidence then that Audi has been sponsoring sporting events for

many years. In the world of winter sports, for example, Audi has been the main sponsor of the German Ski Association (DSV) for almost three decades and has also partnered 14 other national alpine teams. In football, we support national and international teams. Audi is also a partner for the German Olympic Sports Confederation.

